

## Description

STM 00-0-0000 0 000 00 0, 00 00, MDF 00 00 00 000 0000000. 000 00000 00 00000 0000 00 Microtec STM 000-0 0000 000 00 0 0000 00 0 00000. 000 000 000 000000 0-0000 00 000 000000.

STM000 0 00 000 00000. 0-0000-00: 32"x40"/40"x48"/40"x55". 000 00 00 00 000 000 0 00000. 000 000 00000 0000 0 0 000 00000 00000.

0 00 00-0-0000-00, 000 0000000. 0000 000 000 000 00000 000000. 000 000 000 000 000 000000. 000 000 000000 00 00 000 000000. 00 0 00000 400 000 00 000 0 000 00000 000 000 0 00000.

STM 0000-00-0-0000-00 00 00, 00 00 00 0 00 0000 00 000 000000.

0 00 0 000 000 0 00 000 00 00 0000 000 0 00000.



**MICROTEC**

# Economic Large format

## Semi-Auto Heat Press Machine

Model No.: STM-40/48/55  
80\*100cm/100\*120cm/100\*140cm

- No Air Compressor Needed
- Digital Temp. & Time Control
- 2 year warranty on entire press



## Feature



000 00 000: 135KG0 40 00 00000 00000 0000 0000 00000 0000 00 0000 0000 00 000.

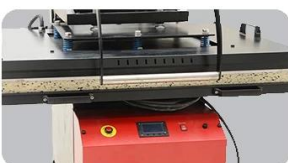

000 000 00000: 0 00 00000 00000 00000 0000 00 00 00000 00 0 00000.



此按钮用于：在紧急情况下立即停止设备运行。



**GY-06** 数字控制器：用于精确控制温度。GY-06 数字控制器具有高精度和稳定性，适用于各种工业应用。

## Specification

产品系列	STM-40/ STM-48/ STM-55
产品尺寸	32"x40"/40"x48"/40"x55"(80x100cm/100x120cm/100x140cm)
产品重量	398kg/ 501kg/ 534kg (含包装)
产品材质	304 不锈钢
产品颜色	GY-06 数字控制器 红色、黑色
产品厚度	28mm
产品电压	220V 单相 / 220V 三相 / 380V 三相
产品功率	5.1KW/ 7.5KW/ 9KW
产品温度范围	0~999℃
产品精度	±0.5%
产品重量	8kg/cm
产品尺寸	154x124x151cm/ 152x142x152cm/ 159x149x159cm
产品重量	398kg/ 501kg/ 534kg (含包装)

## Application

STM 系列设备广泛应用于工业加热、干燥、烘焙等领域，STM 数字控制器广泛应用于各种工业设备的温度控制。



Gallery



# STM Large Format Semi-Automatic Heat press

Model. No.: STM-40/48/55

## Feature:

- ◆ Auto open, large format
- ◆ Digital Temperature & Time Control
- ◆ Automatic Alarm
- ◆ 1 year warranty on entire press
- ◆ Wooden Package

## Specification:

- ◆ Machine Type: Auto Release, Clamshell
- ◆ Platen Size: 32"x40"/40"x48"/40"x64"  
(80x100cm/ 100x120cm/100x140cm)
- ◆ Under Plate: Draw-out
- ◆ Controller: GY-06 Digital Time & Temp. Control
- ◆ Printable Articles: Up to 20mm Thickness
- ◆ Gas Spring Control: Yes
- ◆ Voltage: 220V 1phase/ 220V 3phase/ 380V 3phase
- ◆ Power: 5.1KW/ 7.5KW/ 9KW
- ◆ Time Range: 0-999 sec.
- ◆ Maximum Temp: 225 C
- ◆ Temperature Accuracy:  $\pm 0.5\%$
- ◆ High Pressure: 8KG/CM
- ◆ Packing Size: 154x124x147cm / 154x142x147cm / 149x159x149cm
- ◆ Gross Weight: 450kg (Wooden Package)





Recycled Cotton Pad



Strong Arm



Emergency Stop Switch



Anti-scald Protection  
Metal Cover



GY-06 Digital  
Time & Temp. Control



Draw-out Under Plate

## Application:

◆Especially for Large Size colth, banner, also for T-shirt, Puzzle, Mouse Pad, Metal Board, Fridge Magnet, Coaster, Slipper, Bag, Cushion etc

## Assembly Drawing:

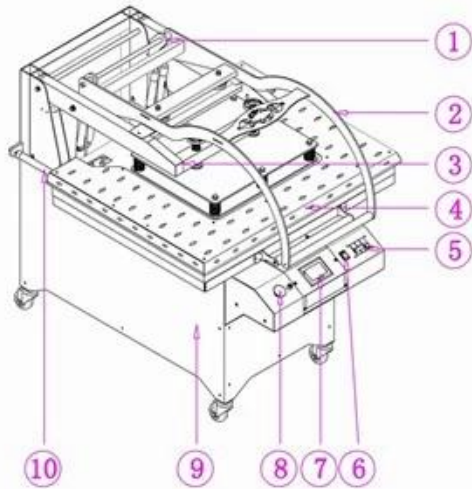

- |                   |                   |                            |                         |
|-------------------|-------------------|----------------------------|-------------------------|
| ① Arm Support     | ② Handle Bar Grip | ③ Davit Arm                | ④ Heat Platen           |
| ⑤ Circuit Breaker | ⑥ Power Switch    | ⑦ GY-06 Digital Controller | ⑧ Emergency Stop Button |
| ⑨ Machine base    | ⑩ Slide Rail      |                            |                         |

## Packing:

The machine is packed in strong wooden package and provide with manual.  
(154x124x147cm / 154x142x147cm / 149x159x149cm)



## Machine Warranty

Microtec 100% 100% 100% 100% 100% 100% 100% 100% 100% 100%. Microtec 100% 100% 100% 100% 100% 100% 100% 100% 100% 100%.

- \* 100% 100% 100% 100% 100% 100%.
- \* 200%
- \* 100% 100% 100% 50% 100%.
- \* 100% 100% 100% 5000%.